

**PIPELINE CONNECTORS**  
**UniAdca CX 402**  
**(Duplex design DN25 – DN40)**

**DESCRIPTION**

The UniAdca CX series pipe connectors are used in steam systems where a simplified and economical maintenance program of steam is desired.

Typical installations are drip service on steam lines, tracing and small process equipment.

Two bolt flange connector permits trap replacement in minutes without disturbing piping.

The CX connector fits all UniAdca steam traps.

Connections are female screwed or flanged.

**MAIN FEATURES**

Remains in-line permanently making replacing of new traps easier and quicker.

UniAdca steam traps can swivel 360° allowing any pipe orientation during installation.

The universal flange allows the trap to be positioned in the correct position, regardless of pipeline configuration.

Built-in strainer.

**OPTIONS:** Socket weld and ANSI flanged connections.

**USE:** Saturated and superheated steam.

**AVAILABLE**

**MODELS:** CX402S - Forged steel construction  
 CX402SS - Stainless steel construction

**SIZES:** DN 1" and DN 1 1/2"  
 DN 25 and DN 40.

**CONNECTIONS:** Female screwed ISO 7/1 Rp (BS21).  
 Flanged EN 1092-1 or ANSI.

**INSTALLATION:** Can be installed in any position according to the type of UniAdca steam trap to be used.

See IMI installation and maintenance instructions.

PMA – Max. allowable pressure 80 bar

TMA – Max. allowable temperature 425 °C

PMO – Max. operating pressure 32 bar

TMO – Max. operating temperature 400 °C

How to order: i.e.CX40S DN20 PN40

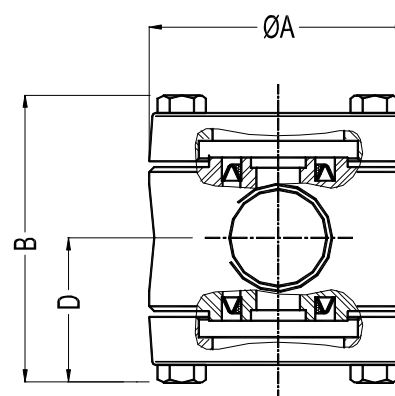
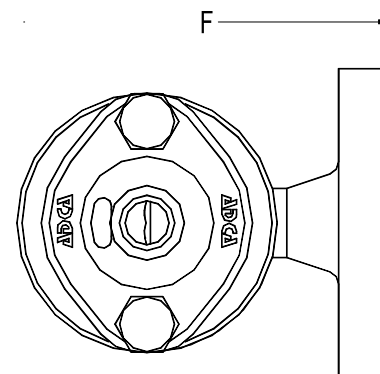
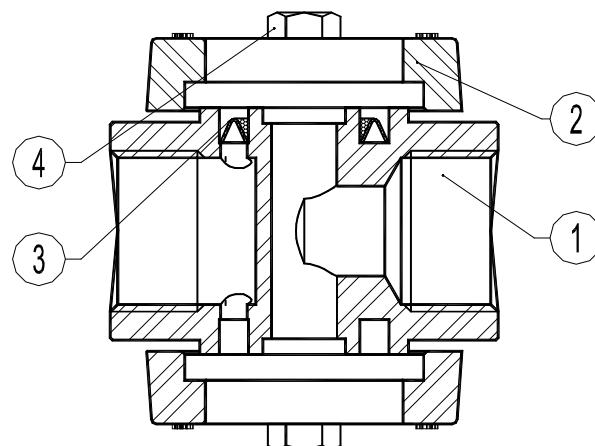

DIMENSIONS (mm)-Screwed					EN 1092-1 Flanges	
SIZE DN	A	B	D	WGT. Kgs	F	WGT. Kgs
25	80	100	19	2,2	160	4,8
40	110	112	50	3,8	230	8,4

MATERIALS			
POS.N r.	DESIGNATION	MATERIAL CX402S	MATERIAL CX402SS
1	Body	P250GH / 1.0460	AISI316 / 1.4401
2	Flange	P250GH / 1.0460	AISI316 / 1.4401
3	* Strainer	AISI304 / 1.4301	AISI304 / 1.4301
4	* Bolts	A4-80	A4-80

\* Available spare parts

We reserve the right to change the design and material of this product without notice.