

FLOAT AND THERMOSTATIC STEAM TRAPS UniAdca FS32

DESCRIPTION

UniAdca FS32 complete stainless steel, maintenance free sealed float and thermostatic (integral air vent) steam traps series are designed for all types of low and medium pressure steam heating and process equipment.

Typical applications include unit heaters, heat exchangers, driers, jacketed vessels and all the applications where continuous drainage is essential.

These traps fit the CX40 UniAdca connectors.

MAIN FEATURES

Modulating discharge.

Discharges condensate at steam temperature.

Unaffected by sudden or wide load and pressure changes.

Excellent air discharge (by thermostatic air vent)

OPTIONS: Equalizing plug, venting connection and drain plug (or blow-off valve on body)

USE : Saturated and superheated steam.

AVAILABLE

MODELS : FS32-4.5 - FS32-10 - FS32-14.

SIZES : DN1/2", 3/4" and 1".
DN15, DN20 and DN25.
According to the pipeline connector.
See IS 1.0910 and IS 1.0915

INSTALLATION : Always in a horizontal plan with the plug pointing downwards.
See IMI installation and maintenance instructions.

PMA – Max. allowable pressure 40 bar
TMA – Max. allowable temperature 400 °C
PMO – Max. operating pressure 14 bar
TMO – Max. operating temperature 235 °C

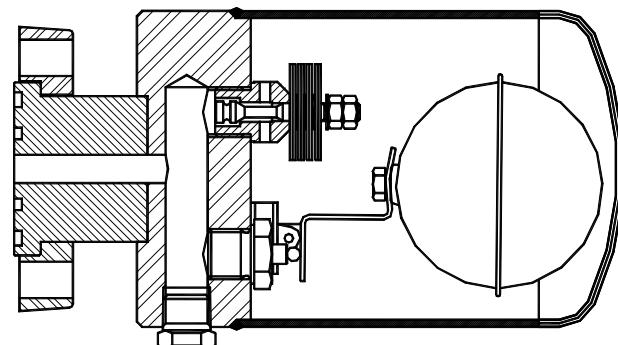
Materials:

AISI316 / 1.4401 throughout

Weight : 2,7 kgs

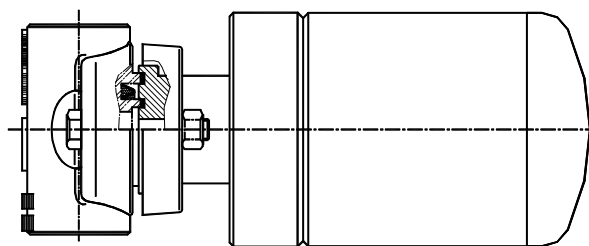
Steam trap plus pipe connector

See IS 1.0965 and IS 1.0970

MAX. DIFFERENTIAL PRESSURE
FS32-4,5 : 4,5 bar
FS32-10 : 10 bar
FS32-14: 14 bar

How to order:

-Steam trap: FS32 (Float and thermostatic steam trap).

-Pipe connector:

-CX40S DN ... (Forged steel pipe connector)

-CX40SS DN ... (Stainless steel pipe connector)

-CX402S DN ... (Forged steel duplex pipe connector)

-CX402SS DN ... (Stainless steel duplex pipe connector)

-The complete set:

FS32XS DN ... (Steel pipe connector CX40S plus FS32 steam trap)

FS32X2S DN ... (Steel pipe duplex connector CX402S plus two FS32 steam traps)

FLOW RATE CAPACITY IN Kgs/h

MODEL	SIZE	DIFFERENTIAL PRESSURE (bar)												
		0,5	1	1,5	2	3	4,5	6	7	8	9	10	12	14
FS32-4,5	15 - 25	200	280	320	360	400	495							
FS32-10	15 - 25	110	140	175	190	230	280	300	330	350	390	405		
FS32-14	15 - 25	70	100	120	140	155	190	210	220	225	230	260	280	300