

ASME Flange Ball Valve Fig. A93D



Split body - Full bore - ANSI 150 - direct mounting construction

Fig. 93D - 150lbs 1/2" -4"

Stainless steel / Carbon steel Investment casting

Temperature range -20°C to 230°C



Certificates:

ATEX Ex II 2GDc IIB/IIC
CE 0036 according to PED 97/23/EC
Firesafe according to BS 6755/2
FDA 21 CFR 177.1550
Sulfide stress cranking NACE MR-01-75

Valve design	ASME B16.34
Face to face:	ASME B16.10
Flange connection	ASME B16.50

ASME Flange Ball Valve Fig. A93D



1/2" - 4" ANSI 150

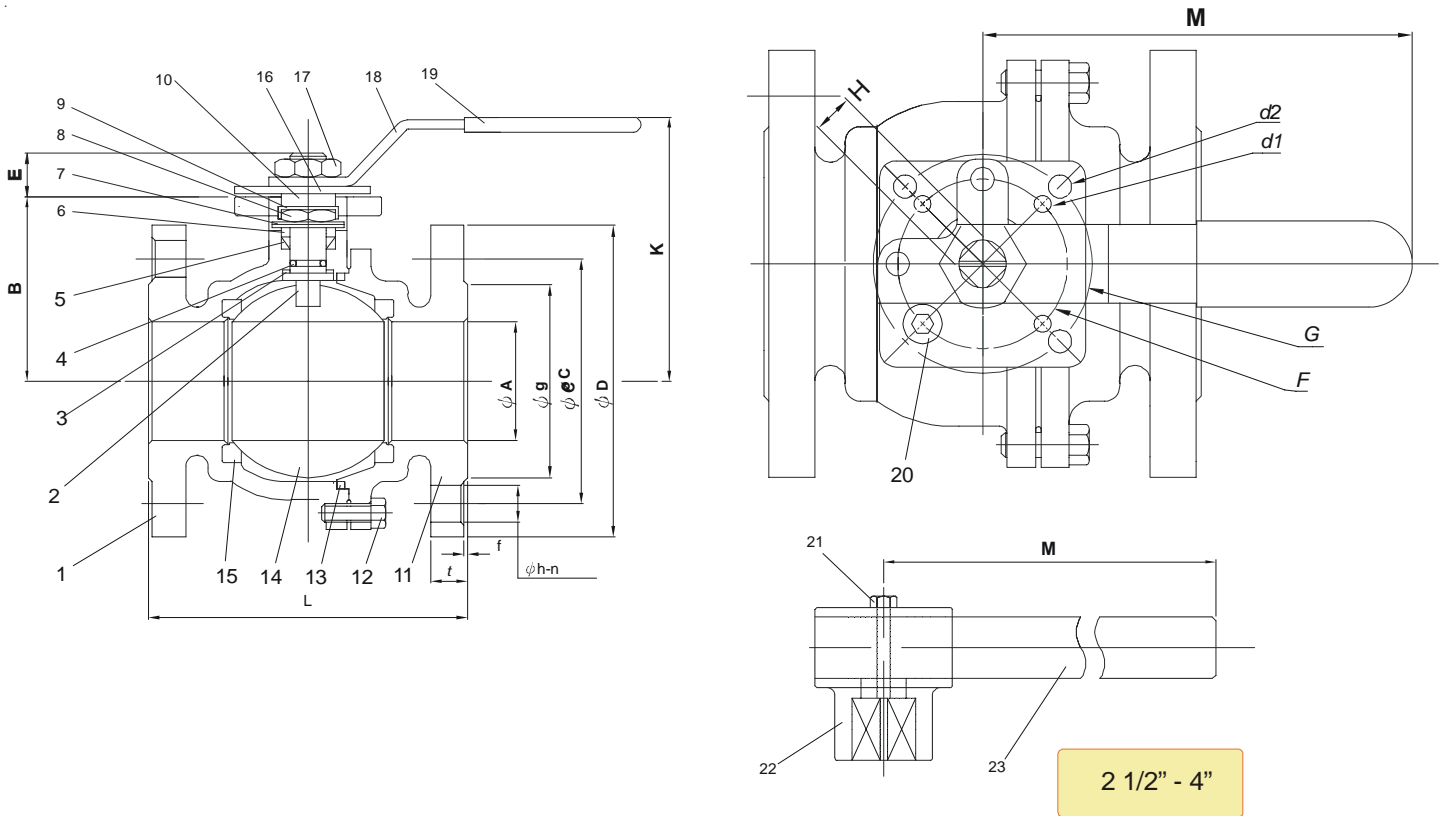

SIZE	A	B	E	L	H	K	M	F	G	d1	d2	CLASS150 FLANGE DIMENSIONS							Weight kg
												D	C	H	N	t	g	f	
1/2"	15	48	11	108	9	80	130	36	42	6	6	89	60.5	16	4	11.5	35	1.6	1.73
3/4"	20	53	11	117	9	80	130	36	42	6	6	98	70	16	4	11.5	43	1.6	2.13
1"	25	59	14	127	11	90	165	42	50	6	7	108	79.5	16	4	11.5	51	1.6	2.92
1-1/4"	32	71	14	140	11	102	165	42	50	6	7	117	89	16	4	12.7	64	1.6	4.02
1-1/2"	38	76	18	165	14	110	205	50	70	7	9.2	127	98.5	16	4	14.3	73	1.6	5.90
2"	50	85	18	178	14	120	205	50	70	7	9.2	152	120.5	19	4	15.9	92	1.6	8.72
2-1/2"	65	93.5	23	190	17	140	300	70	102	9.2	11.4	178	139.5	19	4	17.8	105	1.6	13.33
3"	80	103	23	203	17	150	340	70	102	9.2	11.4	190	152.5	19	4	19.1	127	1.6	17.03
4"	100	132	25	229	22	180	420	102	125	11.4	13.5	229	190.5	19	8	24.0	157	1.6	28.98

ASME Flange Ball Valve Fig. A93D



1/2" - 4" ANSI 150

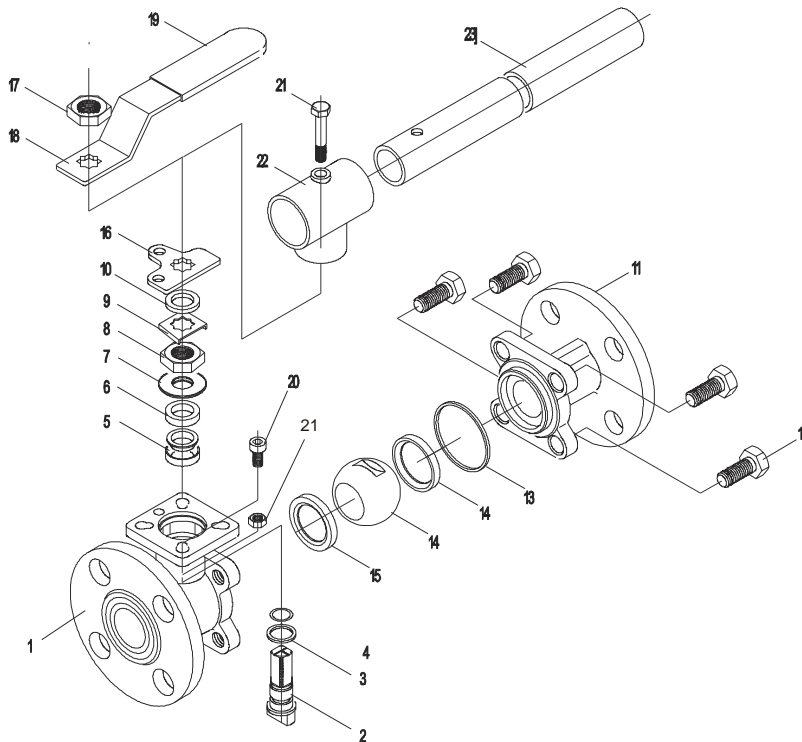

Item	Part	Material
1	Body part	CF8M/ WCB
2	Stem	316
3	Thrust washer	RPTFE
4	O-ring	Viton
5	Stem packing	PTFE / Graphite
6	Stem seal follower	316
7	Disk washer	301
8	Stem nut	304
9	Saddle lock	304
10	Washer	304
11	Flange part	CF8M / WCB
12	Body screw	304
13	Gasket	PTFE / Graphite
14	Ball	316
15	Seat	PTFE / RPTFE
16	Stop plate	304
17	Handle nut	304
18	Handle	304
19	Sleeve	PVC
20	Stop pin	304
21	Fastening nut	304
22	Lever adapter	CF8M
23	Handle	304

ANSI Flange Ball Valve Fig. A93D



Pressure / temperature graph

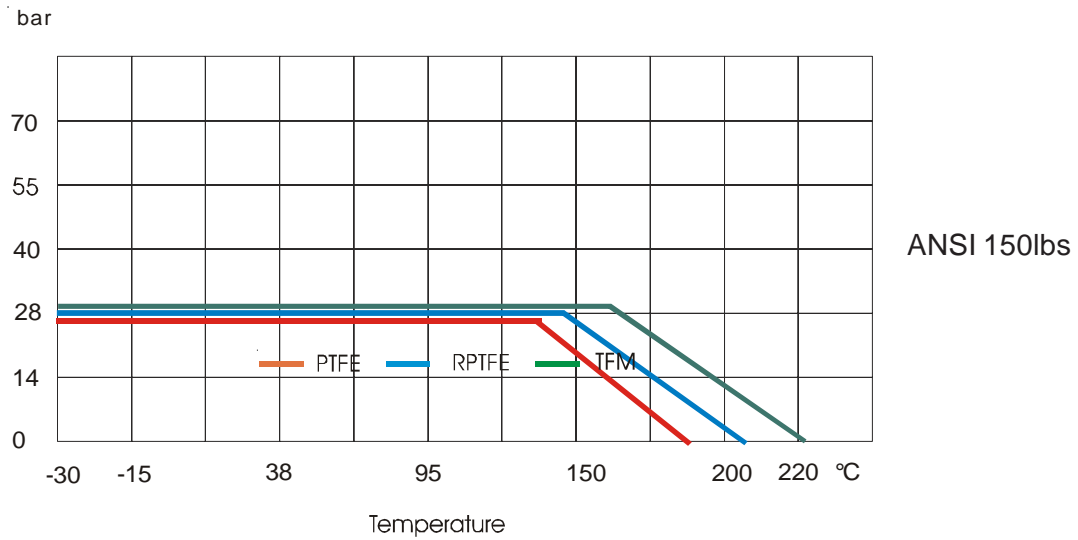

Minimum temperature for stainless steel body only, for carbon steel body -10°C

Break torques (Nm) for lubricating media , at delta p= 0 bar, safety factor +30% included

Size	1/2"	3/4"	1"	1 1/4"	1 1/2"	2"	2 1/2"	3"	4"
ANSI 150 lbs	8	10	12	16	26	31	70	81	162