

Bälgtätande kägelventil

Protek-2230 Pn 16
Protek-2330 Pn 25
Protek-2430 Pn 40
Dn 15 - Dn 200

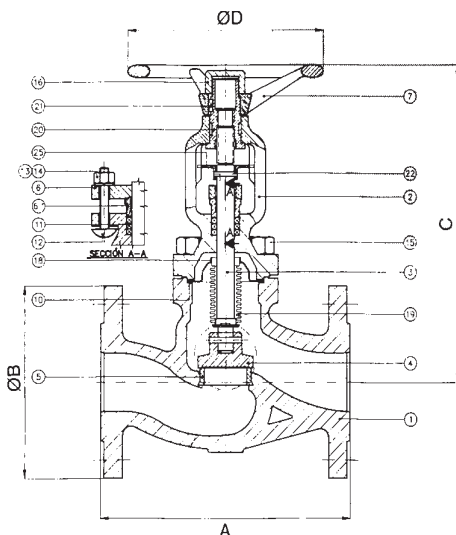

- 1 Hus
- 2 Överdel
- 3 Spindel
- 4 Kägla
- 5 Säte
- 6 Packbox
- 7 Ratt
- 10 Packning
- 11 Packning
- 12 Bult
- 13 Mutter
- 14 Bricka
- 15 Bult
- 16 Rattmutter
- 18 Bröst
- 19 Bälgs
- 20 Bussning
- 22 Stift
- 25 Stoppkloss
- 26 Stift

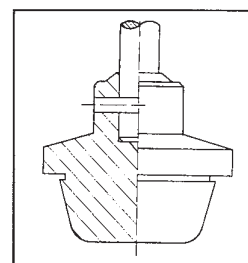

Kan levereras
med reglerkägla

DN	PN 16 PN 25 PN 40			C	D	kv.	Vikt	Stighöjd Spindel		
	A	ØB	ØB					ØB	2230/2330	2430
15	130	95	95	95	200	120	3,5	4,2	10	10
20	150	105	105	105	210	120	6,8	5,2	8	8
25	160	115	115	115	220	140	10,5	7	8	8
32	180	140	140	140	230	140	18,3	8,1	9	9
40	200	150	150	150	250	180	27,9	13	10	10
50	230	165	165	165	260	180	41,6	16	13	13
65	290	185	185	185	340	200	78,1	24	18	18
80	310	200	200	200	350	200	116,2	29	20	20
100	350	220	235	235	370	250	188,3	44	25	25
125	400	250	270	270	510	275	277,1	70	37	40
150	480	285	300	300	545	330	402,0	102	43	40
200	600	340	360	375	630	400	718	205	52	52

Alla mått i mm

Materialspecifikation:

- 1 Hus
- 2 Ratt
- 3 Säte
- 4 Sätetsring
- 5 Spindel
- 6 Spindeltätning
- 7 Bult
- 8 Bälgs

Protek-2230

- GGG
GG40
x 20 CrNi
x 20 CrNi
x 12 CrNi S 18.8
Grafit
Stål 5.6. Zn
1.4541

Protek-2330

- 40.3
GG40
x 20 CrNi
x 20 CrNi
x 12 CrNi S 18.8
Grafit
Stål 5.6. Zn
1.4541

Protek-2430

- GS-C25
GG40
x 20 CrNi
x 20 CrNi
x 12 CrNi S 18.8
Grafit
Stål 5.6. Zn
1.4541